

DSCP20



Programmable 2-wire Temperature Transmitters, DIN-mount

DESCRIPTION

The DSCP20 2-wire transmitter is designed for measuring temperature using thermocouples or RTDs (Figure below). The input type, measurement range, and other features are software configurable. A PC, the DSCX-887 and DSCX-416 interface cables, and the DSCX-895 configuration software are required to configure the transmitter. Communication is serial RS-232C.

The DSCP20 can interface to 12 industry-standard thermocouple types: J, K, T, E, R, S, B, N, L, U, C, and D. Cold junction compensation is selectable as either internal or external. Three RTD types, Pt 100, Ni 100, and Cu 50* can be interfaced in a 2-, 3- or 4-wire connection. All inputs are linearized using up to 23 points of interpolation, and total errors are less than $\pm 0.2\%$.

Other configurable features include: zero point and input range adjustment, output response for open or short-circuit sensor or cable failure, normal or inverted output, ripple suppression for 50Hz or 60Hz, and output time response. The DSCX-895 configuration software allows query, print-out and saving of configuration settings, display of input measurement value, and display of interpolation table points.

*Call factory for Cu RTD information.

FEATURES

- Low-cost Non-isolated 4-20mA Transmitter
- No Power Supply Required, Powered from Output Loop Current
- Interfaces to All Standard Thermocouples and RTDs
- Software-configurable Input Type and Range
- Open and Short-circuit Input Detection
- Configurable with or without Output Loop Power Connected
- Mounts on Standard DIN-rail
- -25°C to $+80^{\circ}\text{C}$ Operating Temperature
- CE Compliant

BENEFITS

- Improved Signal Integrity Over Long Distances
- Shielded Twisted-pair Wiring Provides Higher EMI Resistance
- Improved Accuracy
- Less Expensive Wiring
- Simplified Maintenance
- Retrofit/Upgrade Flexibility

APPLICATIONS

- Automotive
- Industrial Equipment
- Calibration and Instrumentation
- HVAC
- Power and Utilities
- Lab and Testing Applications

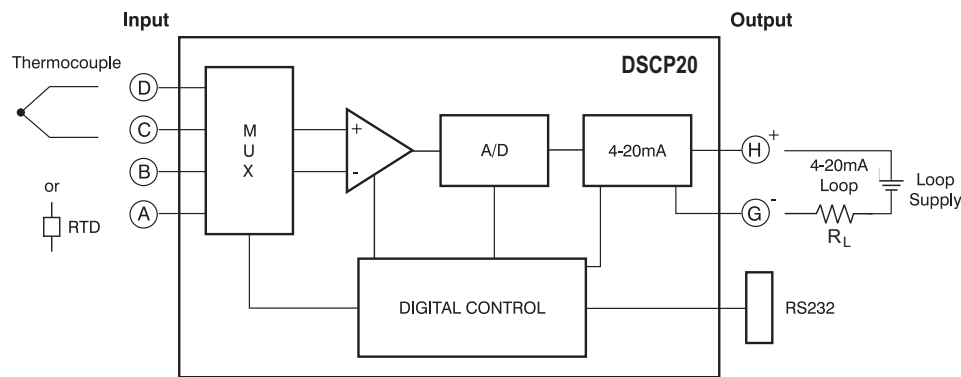

DSCP20 Block Diagram



The following grounding condition must be observed when programming the instrument.

If one of the power supply or input wires is grounded to earth, a PC without an earth connection **must** be used when programming (e.g. a laptop running on batteries).

Under no circumstances should a PC be used running from a power supply with an earth connection, as this will damage the module.

Thermocouple Type and Material

Type	Material	Type	Material
B	Pt30Rh-Pt6Rh	R	Pt13Rh-Pt
E	NiCr-CuNi	S	Pt10Rh-Pt
J	Fe-CuNi	T	Cu-CuNi
K	NiCr-Ni	U	Cu-CuNi
L	Fe-CuNi	C	W5 Re/W26 Re
N	NiCrSi-NiSi	D	W3 Re/W25 Re

Specifications Typical* at T_A = +25°C, 24VDC Loop Supply Voltage, R_L = 250Ω; PT100, 3-wire, 0-600°C

Module	DSCP20
Input Range, Thermocouple Thermocouple Types: B, E, J, K, N, R, S, T, L, U, C, D Cold Junction Compensation Internal External Input Resistance	Reference Table 1 Incorporated Pt 100 0 to 60°C, Configurable >10MΩ
Input Range, RTD RTD Types: Pt 100, Ni 100 RTD Excitation Current Input Resistance Lead Resistance	Reference Table 1 ≤0.20mA >10MΩ ≤30Ω per Lead
Output Range Output Noise Loop Supply Voltage Reverse Supply Protection Load Resistance Output Response for Input Failure Output Time Response	4-20mA or Inverse 20-4mA <1% p-p 12-30VDC Continuous See Note 1 Configurable to Hold Value of Output Immediately Prior to Input Failure, or Value Between 4 and 21.6mA Configurable, see Table 2
Accuracy ⁽²⁾	±0.1% Span (typ), ±0.2% Span (max) [†]
Linearity	±0.03% Span (typ), ±0.1% Span (max)
Stability	±(0.015%+0.015°C)/°C
Mechanical Dimensions (h)(w)(d)	2.44" x 0.67" x 2.56" (62mm x 17mm x 65mm)
Mounting	DIN EN 50022-35x7.5 or EN 50035-G32
Housing Material	Polyamide, Flammability Class V2 According to UL 94
Environmental Operating Temp. Range Storage Temp. Range Relative Humidity Emissions Immunity	-25°C to +80°C -40°C to +80°C 0 to 75% Noncondensing EN50081-2 (Radiated, Conducted) EN50082-2 (ESD, RF, EFT)

NOTES:

*Contact factory or your local Dataforth sales office for maximum values.

$$(1) \text{ Load Resistance: } R_L(\text{max}) = \frac{\text{Loop Supply (V)} - 12\text{V}}{I_{\text{OUTPUT}}(\text{max})}$$

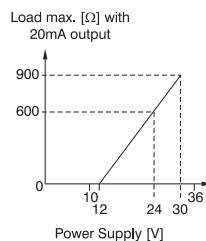

(2) Includes hysteresis, conformity and repeatability at reference conditions. Does not include CJC error.

(3) Shipped as PT 100 for 3-wire connection, 0 to 600°C range, 4-20mA output, open circuit detect = 21.6mA output.

(4) Downloadable from website.

(5) Many different ranges may be programmed as long as the min/max limits are observed. For minimum range examples, a K type thermocouple could be programmed for +30°C to +78.5°C, or +100°C to +149°C, or +900°C to +995°C, and so on.

Table 1: Input Range-Thermocouple and RTD

Measured Variables	Measuring Ranges		
	Limits	Span (min)	Span (max)
RTD: 2-, 3-, or 4-wire Pt 100, Standard IEC 60 751 Ni 100, Standard DIN 43 760	-200 to +850°C -60 to +250°C	50°C 50°C	850°C 250°C
Thermocouple Type B, E, J, K, N, R, S, T; Standard IEC 60 584-1 Type L and U; Standard DIN 43 710 Type C: W5 Re/W26 Re, Type D: W3 Re/W25 Re; Standard ASTM E 988-90	According to Type	2mV ⁽⁵⁾	80mV ⁽⁵⁾

Table 2: Output Response Times

Measuring Mode	Open Sensor Circuit	Short-Circuit	Possible Response Times [s]						
			1.5	2.5	3.5	6.5	11	20.5	40
TC int. comp.	active	–	1.5	2.5	3.5	6.5	11	20.5	40
TC int. comp.	off	–	1.5	2.5	3.5	6.5	13.5	24.5	49.5
TC ext. comp.	active	–	1.5	2.5	3.5	6.5	11	20.5	40
TC ext. comp.	off	–	1.5	2.5	4	6.5	13.5	24.5	48.5
RTD 2L	active	–	2	2.5	3	5	9.5	17.5	33.5
RTD 3L, 4L	active	active	2	2.5	4	6.5	11.5	21	40.5
RTD 2L, 3L, 4L	off	off	1.5	2.5	3.5	7.5	14	26.5	50.5

†Additional Errors

Low Measuring Range Resistance Thermometer (<200°C Span) Thermocouples (<500°C Span)		±0.015% Span (typ), ±0.05% Span (max) ±0.015% Span (typ), ±0.05% Span (max)
High Initial Value	Factor: Error:	±0.0002 (typ), ±0.0005 (max) (Factor)*(Initial Value/Span)*100 [%]
Influence of Lead Resistance		±0.01% per Ω
Internal Cold Junction Compensation		±(0.5°C/Span)*(100) [%]

Ordering Information

Model	Input Range/Description	Output Range
DSCP20 (Basic Configuration) ⁽³⁾	Configurable RTD or Thermocouple, User Programmed	4-20mA, or Inverted

Accessories

Model	Description
DSCX-887	PC-interface Cable
DSCX-416	Module-interface Cable
DSCX-895 ⁽⁴⁾	Configuration Software

Table 3: Temperature Measuring Ranges

Measuring Range Examples [°C]	Resistance Thermometers ⁽¹⁾		Thermocouples ⁽²⁾											
	Pt100	Ni100	B	E	J	K	L	N	R	S	T	U	C ⁽³⁾	D ⁽⁴⁾
0...40	X			X	X		X							
0...50	X	X		X	X	X	X				X	X		
0...60	X	X		X	X	X	X				X	X		
0...80	X	X		X	X	X	X	X			X	X		
0...100	X	X		X	X	X	X	X			X	X		
0...120	X	X		X	X	X	X	X			X	X		
0...150	X	X		X	X	X	X	X			X	X	X	
0...200	X	X		X	X	X	X	X			X	X	X	X
0...250	X	X		X	X	X	X	X			X	X	X	X
0...300	X			X	X	X	X	X	X	X	X	X	X	X
0...400	X			X	X	X	X	X	X	X	X	X	X	X
0...500	X			X	X	X	X	X	X	X		X	X	X
0...600	X			X	X	X	X	X	X	X		X	X	X
0...800	X		X	X	X	X	X	X	X	X			X	X
0...900			X	X	X	X	X	X	X	X			X	X
0...1000			X	X	X	X		X	X	X			X	X
0...1200			X		X	X		X	X	X			X	X
0...1500			X						X	X			X	X
0...1600			X						X	X			X	X
0... 1800			X										X	X
0... 2000													X	X
50...150	X	X		X	X	X	X	X			X	X		
100...300	X			X	X	X	X	X			X	X	X	X
200...500	X			X	X	X	X	X	X	X		X	X	X
300...600	X			X	X	X	X	X	X	X		X	X	X
600...900			X	X	X	X	X	X	X	X			X	X
600...1000			X	X	X	X		X	X	X			X	X
900...1200			X		X	X		X	X	X			X	X
600...1600			X						X	X			X	X
600...1800			X										X	X
-10...40	X	X		X	X	X	X					X		
-30...60	X	X		X	X	X	X	X			X	X		
Measuring Range Limits [°C]	-200 to 850	-60 to 250	0 to 1820	-270 to 1000	-210 to 1200	-270 to 1372	-200 to 900	-270 to 1300	-50 to 1769	-50 to 1769	-270 to 400	-200 to 600	0 to 2315	0 to 2315

NOTES:
 (1) Minimum span is 15Ω when the end value⁽³⁾ is less than or equal to 400Ω. Minimum span is 150Ω when the end value⁽³⁾ is greater than 400Ω and not exceeding 4000Ω. The ratio of the min value to the span must be less than or equal to 10. For two-wire connections, the end value is made up of the measured end value (Ω) plus the total resistance of the leads.
 (2) Range of span is 2mV (min) to 80mV (max). The ratio of the min value to the span must be less than or equal to 10.
 (3) W5 Re W26 Re (ASTM E 988-90)
 (4) W3 Re W25 Re (ASTM E 988-90)

Electrical Connections

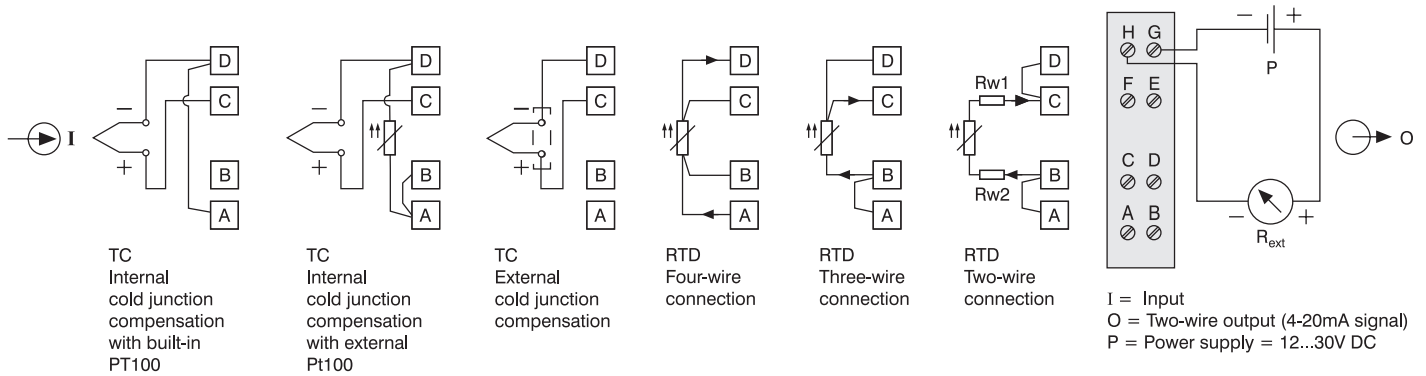

Accessories and Spare Parts

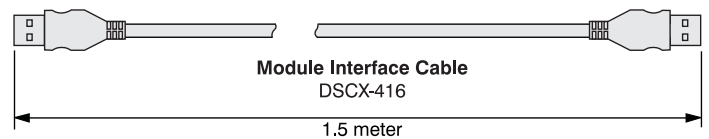
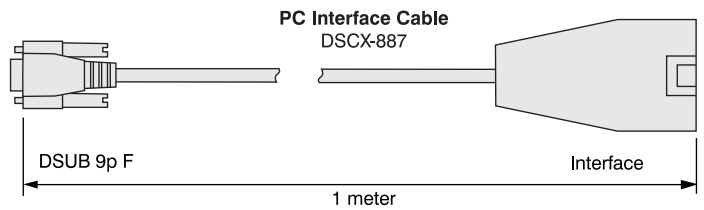
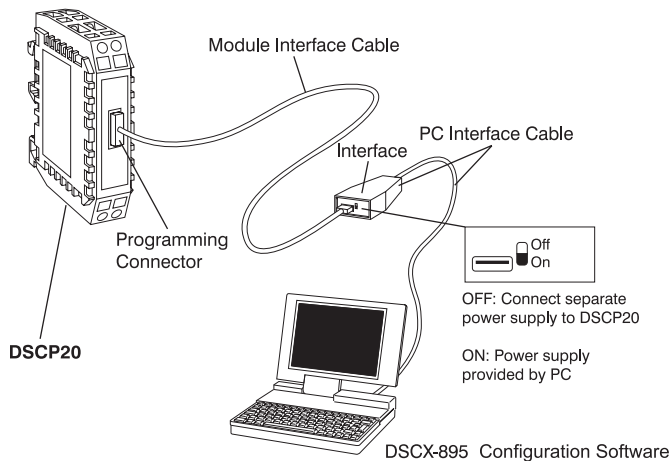

Example of the set-up for programming a DSCP20 without the power supply. For this case, the switch on the interface must be set to "ON". The DSCX-895 configuration software is downloadable from the website.

Dimensions

Dimensions: inches (millimeters)

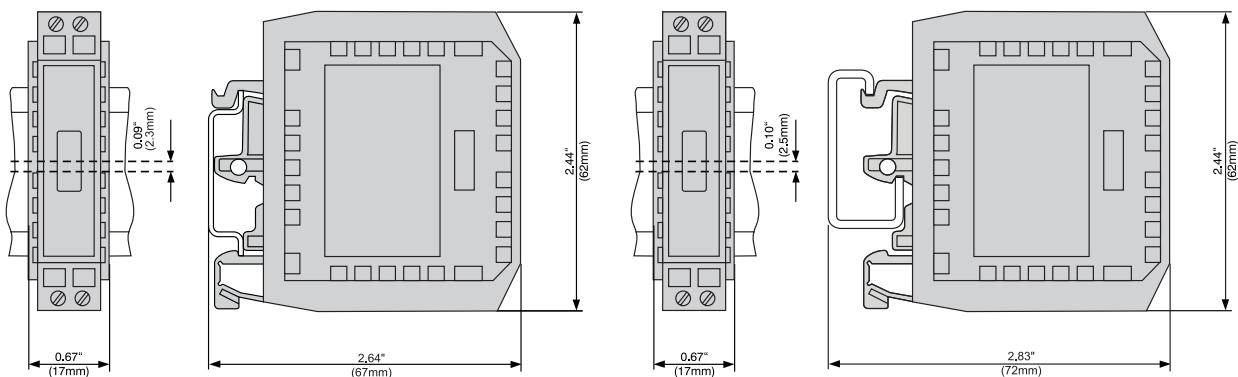

DSCP20 Clipped onto a Top-hat Rail EN 50-022-35 x 7.5

DSCP20 Clipped onto a Rail "G" EN 50-035-G32