

8B37



Non-linearized Thermocouple-input Modules

DESCRIPTION

The 8B37 module family is an optimal solution for monitoring real-world process signals and providing high-level signals to a data acquisition system. Each 8B37 nonlinearized module isolates, filters, and amplifies a single channel of temperature input from a Thermocouple-input signal and provides an analog voltage output (Figure below).

The 8B37 can interface to industry-standard thermocouple types J, K, T, R, and S and has an output signal of 0 to +5V. Each module is cold junction compensated to correct for parasitic thermocouples formed by the thermocouple wire and screw terminals on the mounting backpanel. Upscale open thermocouple detect is provided by an internal pull-up resistor.

Signal filtering is accomplished with a 3-pole filter optimized for time and frequency response which provides 70dB of normal-mode rejection at 60Hz. One pole of this filter is on the field side of the isolation barrier for anti-aliasing, and the other two are on the system side.

A special input circuit on the 8B37 module provides protection against accidental connection of power-line voltages up to 240VAC. Clamp circuits on the I/O and power terminals protect against harmful transients.

The modules are designed for installation in Class I, Division 2 hazardous locations and have a high level of immunity to environmental noise.

FEATURES

- Interfaces to Types J, K, T, R, and S Thermocouples
- High-level Voltage Output
- 1500Vrms Isolation
- ANSI/IEEE C37.90.1 Transient Protection
- Input Protection to 240VAC Continuous
- 120dB CMR
- 70dB NMR at 60Hz
- ±0.05% Accuracy
- ±0.02% Linearity
- Low Drift with Ambient Temperature
- Accurate CJC -40°C to +85°C
- UL/cUL Listed
- CE Compliant
- ATEX Compliance Pending
- Manufactured per RoHS III Directive 2015/863
- Mix and Match Module Types on Backpanel

BENEFITS

- Protects User Equipment from Lightning and Industrial Equipment Power-line Voltage
- Reduces Electrical Noise in Measured Signals
- Convenient System Expansion and Repair

APPLICATIONS

- Designed for Embedded Applications
 - PC/104 Embedded Solutions
 - Compact PCI Systems
 - VMEbus Systems
 - PXI Systems
- Designed for Industrial Plant Environments
- High-vibration Environments

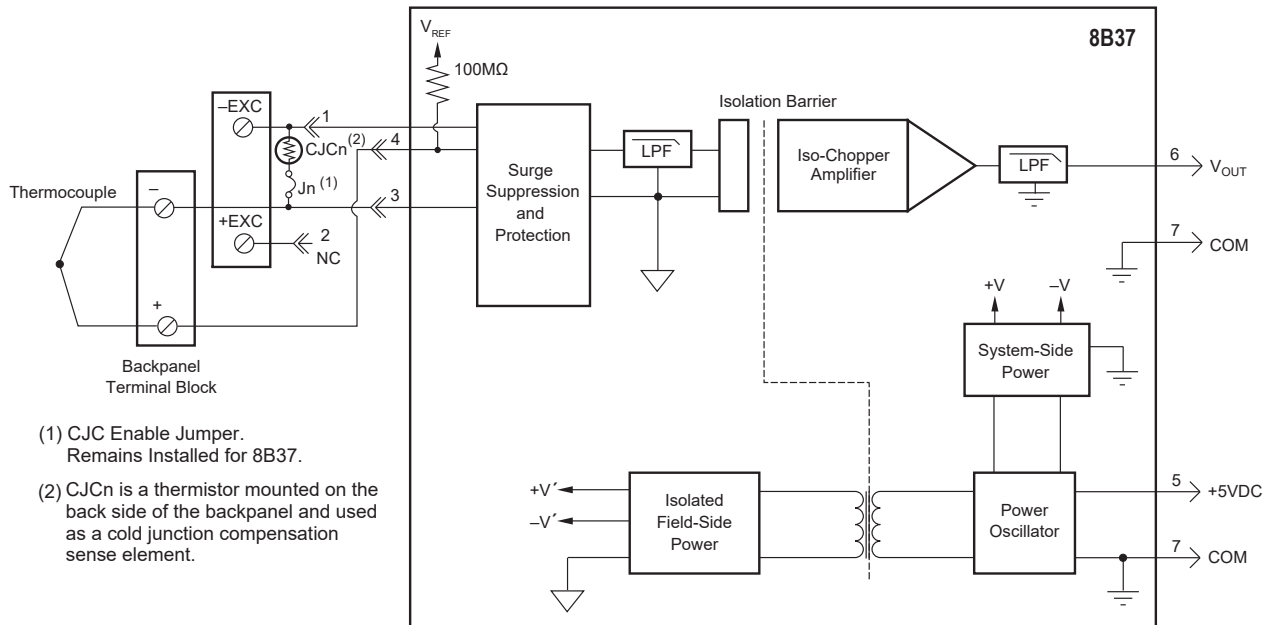

- (1) CJC Enable Jumper. Remains Installed for 8B37.
- (2) CJCn is a thermistor mounted on the back side of the backpanel and used as a cold junction compensation sense element.

8B37 Block Diagram - [For Module Dimensions and Pinouts. See Page 3-40](#)

Specifications Typical* at T_A = +25°C and +5VDC power

Module	8B37
Input Range	See Ordering Information
Input Bias Current	-25nA
Input Resistance	
Normal	50MΩ
Power Off	200kΩ
Overload	200kΩ
Input Protection	
Continuous ⁽¹⁾	240VAC
Transient	ANSI/IEEE C37.90.1
CMV, Input to Output	1500Vrms (max)
Transient, Input to Output	ANSI/IEEE C37.90.1
CMR (50Hz or 60Hz)	120dB
NMR	70dB at 60Hz
Accuracy	See Ordering Information
Linearity	±0.02% Span
Stability	
Offset	±20ppm/°C
Gain	±50ppm/°C
Noise	
Output, 100kHz	250μVrms
Bandwidth, -3dB	3Hz
Response Time, 90% Span	150ms
Output Range	0V to +5V
Output Protection	Continuous Short-to-Ground
Transient	ANSI/IEEE C37.90.1
Cold Junction Compensation	
Accuracy, 25°C	±0.5°C
Accuracy, -40°C to +85°C (J,K,T)	±1.5°C
Accuracy, -20°C to +65°C (R,S)	±3.0°C
Accuracy, -40°C to +85°C (R,S)	±5.0°C
Open Input Response	Upscale
Open Input Detection Time	<10s
Power Supply Voltage	+5VDC ±5%
Power Supply Current	30mA
Power Supply Sensitivity	±75ppm/%
Mechanical Dimensions (h)x(w)x(d)	1.11" x 1.65" x 0.40" (28.1mm x 41.9mm x 10.2mm)
Environmental	
Operating Temperature Range	-40°C to +85°C
Storage Temperature Range	-40°C to +85°C
Relative Humidity	0 to 95% Noncondensing
Emissions EN61000-6-4	ISM, Group 1
Radiated, Conducted	Class A
Immunity EN61000-6-2	ISM, Group 1
RF	Performance A ±0.5% Span Error
ESD, EFT	Performance B

NOTES:

*Contact factory or your local Dataforth sales office for maximum values.

(1) 240VAC between +Input terminal and -Input, +EXC, or -EXC terminals.

120VAC between -Input and +EXC or -EXC terminals.

120VAC between +EXC and -EXC terminals.

(2) Includes linearity, hysteresis, and repeatability. Does not include CJC accuracy.

Ordering Information

Model	TC Type†	Input Range	Output Range	Accuracy ⁽²⁾	
				±0.05%	±0.43°C
8B37J	J	-100°C to +760°C (-148°F to +1400°F)	0V to +5V	±0.05%	±0.43°C
8B37K	K	-100°C to +1350°C (-148°F to +2462°F)	0V to +5V	±0.05%	±0.73°C
8B37T	T	-100°C to +400°C (-148°F to +752°F)	0V to +5V	±0.05%	±0.25°C
8B37R	R	0°C to +1750°C (+32°F to +3182°F)	0V to +5V	±0.05%	±0.88°C
8B37S	S	0°C to +1750°C (+32°F to +3182°F)	0V to +5V	±0.05%	±0.88°C

†Thermocouple Alloy Combinations

Standards: DIN IEC 584, ANSI MC96-1-82, JIS C 1602-1981

Type	Material
J	Iron vs. Copper-nickel
K	Nickel-chromium vs. Nickel-aluminum
T	Copper vs. Copper-nickel
R	Platinum-13% Rhodium vs. Platinum
S	Platinum-10% Rhodium vs. Platinum

Installation Notes

- 1) This Equipment is Suitable for Use in Class I, Division 2, Groups A, B, C, D, or Non-hazardous Locations Only.
- 2) WARNING - Explosion Hazard - Substitution of Any Components May Impair Suitability for Class I, Division 2.
- 3) WARNING - Explosion Hazard - Do Not Disconnect Equipment Unless Power Has Been Switched Off or the Area is Known to be Non-hazardous.