

# 8B30/31



## Voltage-input Modules, Narrow Bandwidth

### DESCRIPTION

The 8B30/31 module family is an optimal solution for monitoring real-world process signals and providing high-level signals to a data acquisition system. Each 8B30 or 8B31 module isolates, filters, and amplifies a voltage input signal and provides an analog voltage output (Figure below).

Signal filtering is accomplished with a 5-pole filter optimized for time and frequency response which provides 70dB of normal-mode rejection at 60Hz. One pole of this filter is on the field side of the isolation barrier for anti-aliasing, and the other four are on the system side.

A special input circuit on the 8B30 and 8B31 modules provides protection against accidental connection of power-line voltages up to 240VAC. Clamp circuits on the I/O and power terminals protect against harmful transients.

Isolation is provided by transformer coupling to suppress transmission of common-mode spikes or surges. The module is powered from +5VDC, ±5%.

The modules are designed for installation in Class I, Division 2 hazardous locations and have a high level of immunity to environmental noise.

### FEATURES

- Accepts Millivolt and Voltage Level Signals
- High-level Voltage Outputs
- 1500Vrms Isolation
- ANSI/IEEE C37.90.1 Transient Protection
- Input Protection to 240VAC Continuous
- 120dB CMR
- 70dB NMR at 60Hz
- ±0.05% Accuracy
- ±0.02% Linearity
- Low Drift with Ambient Temperature
- UL/cUL Listed
- CE Compliant
- ATEX Compliance Pending
- Manufactured per RoHS III Directive 2015/863
- Mix and Match Module Types on Backpanel

### BENEFITS

- Protects User Equipment from Lightning and Industrial Equipment Power-line Voltage
- Reduces Electrical Noise in Measured Signals
- Convenient System Expansion and Repair

### APPLICATIONS

- Designed for Embedded Applications
  - PC/104 Embedded Solutions
  - Compact PCI Systems
  - VMEbus Systems
  - PXI Systems
- Designed for Industrial Plant Environments
- High-vibration Environments

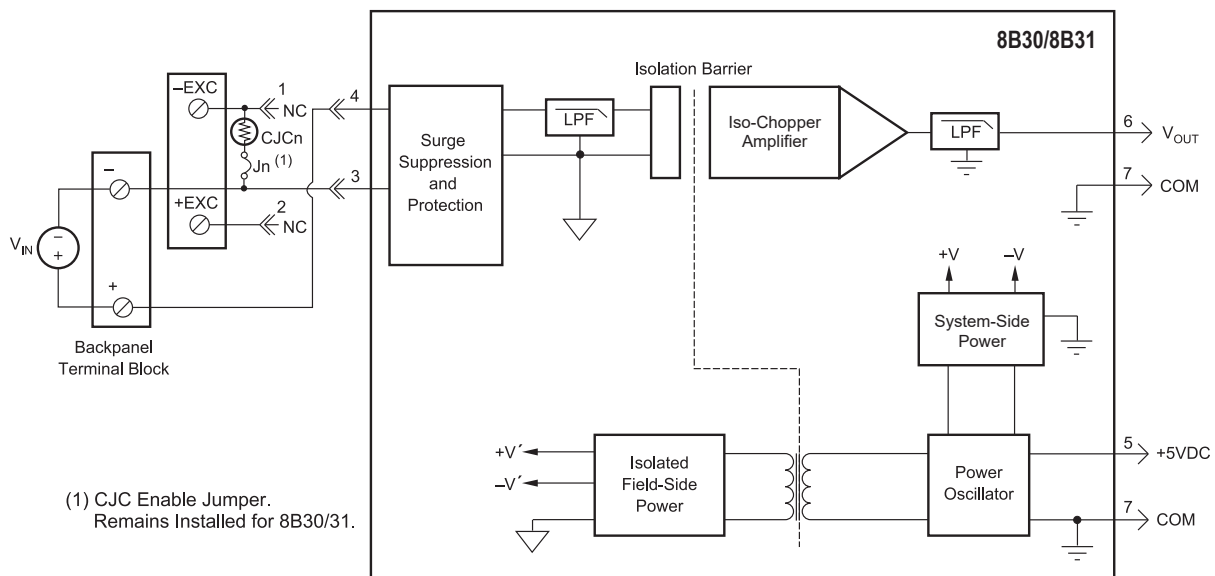

8B30/31 Block Diagram - For Module Dimensions and Pinouts, See Page 3-40

**Specifications** Typical\* at T<sub>A</sub> = +25°C and +5VDC Power

Module	8B30	8B31
Input Range	±10mV to ±100mV	±1V to ±60V
Input Bias Current	±0.5nA	±0.05nA
Input Resistance		
Normal	50MΩ	500kΩ (min)
Power Off	100kΩ	500kΩ (min)
Overload	100kΩ	500kΩ (min)
Input Protection		
Continuous <sup>(1)</sup>	240VAC	240VAC
Transient	ANSI/IEEE C37.90.1	ANSI/IEEE C37.90.1
CMV, Input to Output	1500Vrms (max)	1500Vrms (max)
Transient, Input to Output	ANSI/IEEE C37.90.1	ANSI/IEEE C37.90.1
CMR (50Hz or 60Hz)	120dB	120dB
NMR	70dB at 60Hz	70dB at 60Hz
Accuracy <sup>(2)</sup>	±0.05% Span	±0.05% Span
Linearity	±0.02% Span	±0.02% Span
Stability		
Offset	±10ppm/°C	±10ppm/°C
Gain	±50ppm/°C	±75ppm/°C
Noise		
Output, 100kHz	250μVrms	250μVrms
Bandwidth, -3dB	3Hz	3Hz
Response Time, 90% Span	160ms	160ms
Output Range	See Ordering Information	See Ordering Information
Output Protection	Continuous Short-to-Ground	Continuous Short-to-Ground
Transient	ANSI/IEEE C37.90.1	ANSI/IEEE C37.90.1
Power Supply Voltage	+5VDC ±5%	+5VDC ±5%
Power Supply Current	25mA	25mA
Power Supply Sensitivity	±75ppm/%	±75ppm/%
Mechanical Dimensions (h)x(w)x(d)	1.11" x 1.65" x 0.40" (28.1mm x 41.9mm x 10.2mm)	1.11" x 1.65" x 0.40" (28.1mm x 41.9mm x 10.2mm)
Environmental		
Operating Temp. Range	-40°C to +85°C	-40°C to +85°C
Storage Temp. Range	-40°C to +85°C	-40°C to +85°C
Relative Humidity	0 to 95% Noncondensing	0 to 95% Noncondensing
Emissions EN61000-6-4	ISM, Group 1	ISM, Group 1
Radiated, Conducted	Class A	Class A
Immunity EN61000-6-2	ISM, Group 1	ISM, Group 1
RF	Performance A ±0.5% Span Error	Performance A ±0.5% Span Error
ESD,EFT	Performance B	Performance B

**NOTES:**

\*Contact factory or your local Dataforth sales office for maximum values.

1) 240VAC between +Input terminal and -Input, +EXC, or -EXC terminals.

120VAC between -Input and +EXC or -EXC terminals.

120VAC between +EXC and -EXC terminals.

2) Includes linearity, hysteresis, and repeatability.

**Ordering Information**

Model	Input Range	Output Range
8B30-01	-10mV to +10mV	-5V to +5V
8B30-02	-50mV to +50mV	-5V to +5V
8B30-03	-100mV to +100mV	-5V to +5V
8B30-04	-10mV to +10mV	0V to +5V
8B30-05	-50mV to +50mV	0V to +5V
8B30-06	-100mV to +100mV	0V to +5V
8B31-01	-1V to +1V	-5V to +5V
8B31-02	-5V to +5V	-5V to +5V
8B31-03	-10V to +10V	-5V to +5V
8B31-04	-1V to +1V	0V to +5V
8B31-05	-5V to +5V	0V to +5V
8B31-06	-10V to +10V	0V to +5V
8B31-07	-20V to +20V	-5V to +5V
8B31-08	-20V to +20V	0V to +5V
8B31-09	-40V to +40V	-5V to +5V
8B31-10	-40V to +40V	0V to +5V
8B31-12	-60V to +60V	-5V to +5V
8B31-13	-60V to +60V	0V to +5V

**Installation Notes**

- 1) This Equipment is Suitable for Use in Class I, Division 2, Groups A, B,C, D, or Non-hazardous Locations Only.
- 2) WARNING - Explosion Hazard - Substitution of Any Components May Impair Suitability for Class I, Division 2.
- 3) WARNING - Explosion Hazard - Do Not Disconnect Equipment Unless Power Has Been Switched Off or the Area is Known to be Non-hazardous.