

LDM485



Fully Isolated Limited Distance Modem, RS-232/485 Converter

Description

The LDM485 is a compact RS-232 to RS-485 converter which features a complete electrical isolation barrier and heavy duty electrical surge protectors. These devices feature a rugged aluminum enclosure small enough to mount on the back panel of typical computer equipment, saving valuable desk and floor space. Isolation is provided by optical couplers and a DC-to-DC converter. The RS-232 connection is through male or female EIA 25-pin connectors. The RS-485 connections are made through convenient solderless screw terminals.

The LDM485 series is designed for full duplex operation over two-wire pairs. Outputs are tri-state, allowing multidropping of up to 64 units. Hardware handshake is available over two separate wire pairs. Data rates are DC to 57.6k bits per second. Six diagnostic LED indicators are provided (see Figure 1) for installation guidance and system troubleshooting. The RS-232 interface supports Request To Send, Clear To Send, Data Set Ready, Received Line Signal Detect, and Data Terminal Ready. A convenient null modem switch is provided for the data lines. Also, a line termination switch connects a line termination resistor and line bias resistors to the RS-485 receive lines. The RS-485 interface supports Request To Send and Clear To Send on separate wire pairs. The LDM485 may be used to convert two sets of send and receive channels by using RTS and CTS circuits as the second data channels. Data rates are the same. The units use 12VAC from a wall-mounted transformer to screw terminals 1 and 2 on the RS-485 connector. Alternately, they can use ±12VDC to pins 9 (+) and 10 (-) of the RS-232 connector.

Features

- Complete Isolation with Optical Couplers and Power DC-to-DC Converter
- Industrial Surge Protection Devices
- Six LED Diagnostic Indicators
- 19.2kbps at 3 Miles (5km), 57.6kbps at 0.5 Miles (0.8 km)
- Request-To-Send, Clear-To-Send Handshake
- Tri-state Outputs for Multidrop Applications, Up to 64 Devices
- Selection of Connectors
- Wide Operating Temperature Range
- Solderless Screw Terminal Field Connections
- CE Compliant

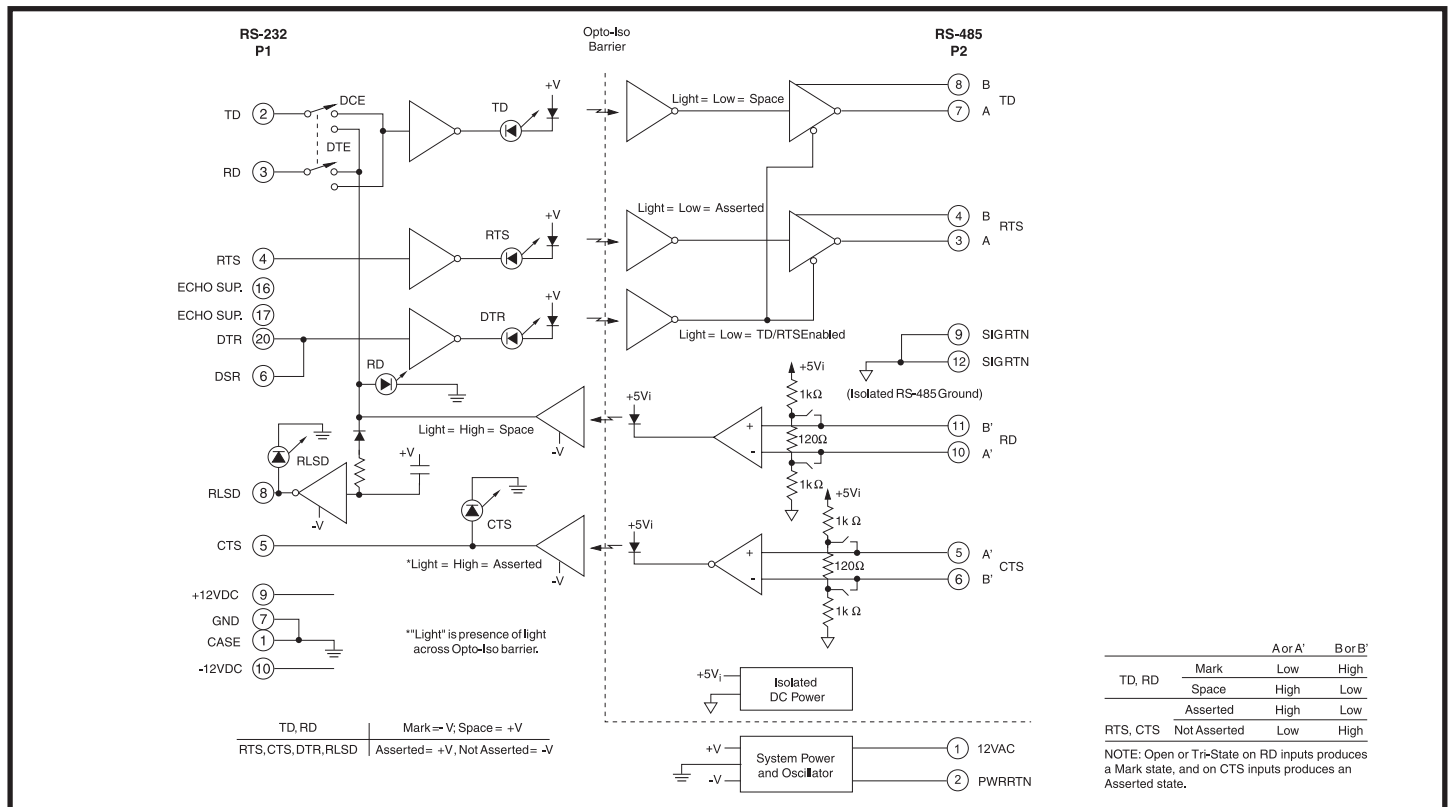

Figure 1: LDM485 Block Diagram

Specifications

Model	LDM485
Bit Rate (bps)	0-57.6k
bps vs Distance	57.6k 38.4k 19.2k 9.6k 4.8k 1.2k-0
Distance(miles) ⁽¹⁾	0.5 1.0 3.0 4.0 5.0 8.0
Distance(km)	0.8 1.6 4.8 6.4 8.1 12.9
Wire Capacitance	Equal to 25pf per foot and up to 32 multidrop units
Maximum Multidrop Units	64
Common Mode Isolation	Surge: 1500V Continuous: 1000V
Differential Mode Surge Protection (9 devices)	(AC input) ANSI/IEEE C37.90.1 (all RS-485 inputs and outputs)
Modes	Asynchronous 4-wire duplex, 2-wire half-duplex, 2-wire simplex
Channel Lines ⁽²⁾ Control Lines ⁽²⁾	TD, RD, RTS, CTS RTS, CTS, DTR, DSR, RLSD
Null Modem Switch	1 (Reverses RS-232 pins 2 and 3)
RS-485 Output Drive RS-485 Input Impedance	60mA max/output 12kΩ min/input
Power AC operation ⁽³⁾ DC operation	12VAC, ±10%, 10W screw terms 1 & 2 +11.5VDC to +17.0VDC at 500mA on pin 9 -11.5VDC to -17.0VDC at 100mA on pin 10
Environmental: Operating Temperature Range Storage Temperature Range Relative Humidity	0°C to +70°C -40°C to +85°C 0 to 95% Noncondensing
Dimensions	6.6" x 2.1" x 1.28" (167.6mm x 53.3mm x 32.5mm)
Weight PT3 and PT3E	7 oz (198g) max 11.0 oz (312g) max
MTTF ⁽⁴⁾	>100,000 hrs

Ordering Information

Model	Description
LDM485-P	Male RS-232 connector
LDM485-S	Female RS-232 connector
LDM485-PT	Male RS-232 connector and U.S. power transformer
LDM485-ST	Female RS-232 connector and U.S. power transformer
LDM485-PE	Male RS-232 connector, European power transformer
LDM485-SE	Female RS-232 connector, European power transformer
PT3	Wall mount U.S. power transformer, 120VAC
PT3E	Wall mount Euro power transformer, 220VAC

RS-232 Pin Descriptions

Pin 1	CASE	Ground
Pin 2	TD [3]	Transmit Data
Pin 3	RD [2]	Receive Data
Pin 4	RTS [7]	Request To Send
Pin 5	CTS [8]	Clear To Send
Pin 6	DSR [6]	Data Set Ready (connected to Data Terminal Ready)
Pin 7	GND [5]	Signal Ground
Pin 8	RLSD [1]	Receive Line Signal Detect
Pin 9	+12VDC	Positive DC Supply Input
Pin 10	-12VDC	Negative DC Supply Input
Pin 16	Echo Sup	Echo Suppression (tie to pin 17 to enable)
Pin 17	Echo Sup	Echo Suppression (tie to pin 16 to enable)
Pin 20	DTR [4]	Data Terminal Ready (connected to Data Set Ready)

RS-485 P2 Pin Desc.

Pin 1	12VAC
Pin 2	PWR RTN
Pin 3	RTS A
Pin 4	RTS B
Pin 5	CTS A'
Pin 6	CTS B'
Pin 7	TD A
Pin 8	TD B
Pin 9	SIG RTN
Pin 10	RD A'
Pin 11	RD B'
Pin 12	SIG RTN

Pin numbers given are for the 25-pin connector with the 9-pin equivalent in [].

NOTES:

- (1) Distances reduced if multidropping more than 32 units; by 30% for 33-48 units; 50% for 49-64.
- (2) TD = Transmit Data, RD = Receive Data, RTS = Request To Send, CTS = Clear To Send, DTR = Data Terminal Ready, DSR = Data Set Ready, RLSD = Received Line Signal Detect.
- (3) 120VAC and 220VAC power transformers are available.
- (4) Ground-benign environmental conditions (no salt atmosphere, <50°C ambient temperature).

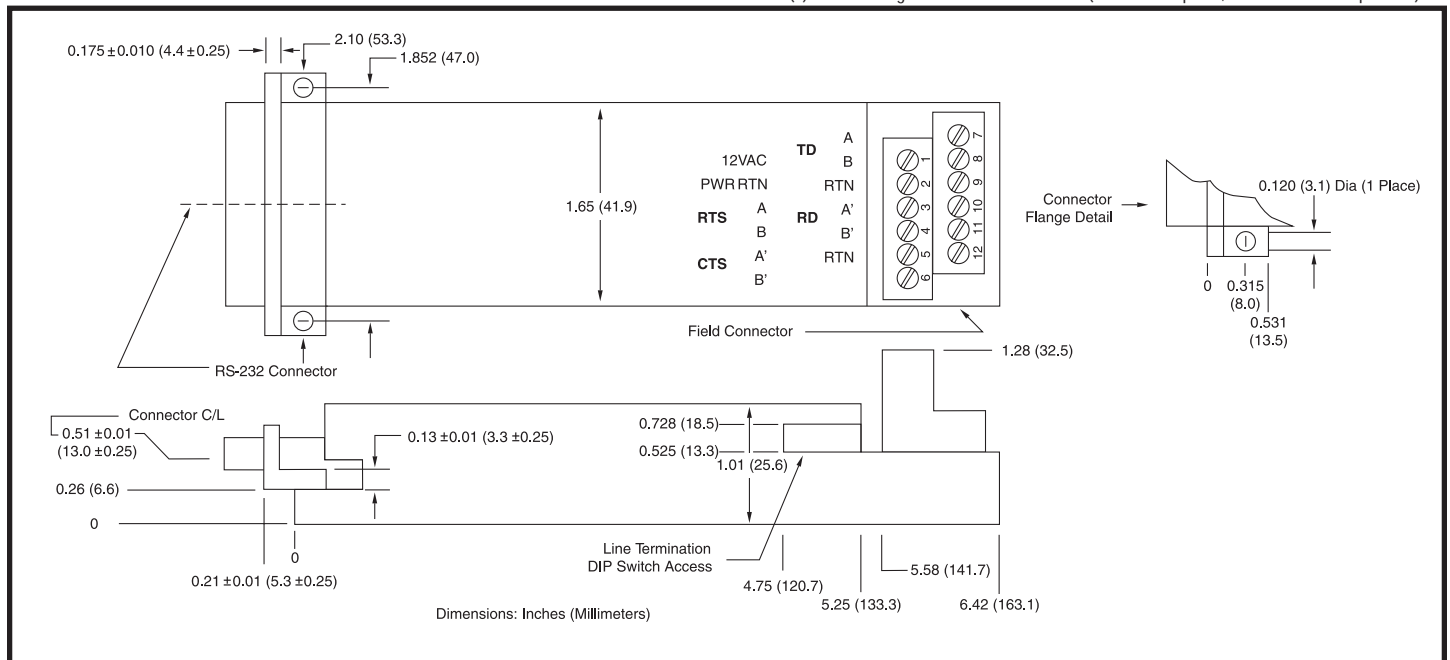

Figure 2: LDM485 Dimensions